



Nitesh Physics

**JEST 2022
PHYSICS**



An Institute of
NET-JRF, IIT-JAM, GATE, JEST, TIFR
CUET Entrance in Physics
Physical Sciences
New Delhi

October 25, 2022

Part A: 1 mark Questions

- The persons named $A, B, C, D, E, F, G, H, I, J$ have come for an interview. They are being called one by one to the interview panel at random. What is the probability that C gives interview before A and A gives before F ?
A. $\frac{1}{6}$ ✓ B. $\frac{1}{10}$ C. $\frac{1}{8}$ D. $\frac{1}{4}$
- The ratio of maximum to minimum resistance that can be obtained with N number of $3 - \Omega$ resistors is?
A. N^2 ✓ B. N C. N^3 D. N^4
- Consider three infinitely long, straight and coplanar wires which are placed parallel to each other. The distance between the adjacent wires is d . Each wire carries a current I in the same direction. Consider points on either side of the middle wire where the magnetic field vanishes. What is the distance of these points from the middle wire?
A. $\frac{2d}{3}$ B. $\frac{2d}{\sqrt{3}}$ C. $\frac{d}{3}$ D. $\frac{d}{\sqrt{3}}$ ✓
- A rod consists of two equal sections of length l each with coefficient of thermal conductivity κ_1 and κ_2 , respectively. One end of the rod is kept at a fixed temperature T_1 and the other end at a temperature T_2 ($T_1 > T_2$). If $\kappa_2 = 2\kappa_1$ then the temperature at the interface is



- $\frac{(2T_1 - 2T_2)}{3}$
 - $\frac{(2T_1 + T_2)}{3}$
 - $\frac{(T_1 + 2T_2)}{3}$ ✓
 - $\frac{(T_1 - 2T_2)}{3}$
- If $f(t)$ is a real and even function of t , which one of the following statements is true about its Fourier transform $F(\omega)$ (here * indicates complex conjugation)?
A. $F^*(\omega) = -F(\omega)$ B. $F^*(\omega) = F(\omega)$ ✓ C. $F^*(-\omega) = F(\omega)$ D. $F(-\omega) = F(\omega)$

6. Consider an ideal gas whose entropy is given by

$$S = \frac{n}{2} \left[\sigma + 5Rkn \frac{U}{n} + 2R \ln \frac{V}{n} \right]$$

where n is the number of moles, σ is a constant, R is the universal gas constant, U is the internal energy and V is the volume of the gas. The specific heat at constant pressure is then given by

- A. $\frac{5}{2}nR$ B. $\frac{7}{2}nR$ ✓ C. $\frac{3}{2}nR$ D. nR

7. A 16-bit analog to digital converter works in the range 0-1 Volt. The least count of the converter is

- A. $0.30mM$ B. $15.26mV$ C. $5.44nV$ D. $15.26\mu V$ ✓

8. A particle in a spherically symmetric potential is known to be in an eigenstate of \vec{L}^2 and L_z with eigenvalues $(l(l+1))\hbar^2$ and $m\hbar$, respectively. What is the value of $\langle l, m | L_x^2 | l, m \rangle$?

- A. $\frac{\hbar^2}{2}(l^2 + l + m^2)$ B. $\hbar^2(l^2 + l + m^2)$ C. $\frac{\hbar^2}{2}(l^2 - l - m^2)$ D. $\frac{\hbar^2}{2}(l^2 + l - m^2)$ ✓

9. A particle of mass m carrying angular momentum l moves in a central potential $V(r) = -\frac{ke^{-ar}}{r}$, where k, a are positive constants. If the particle undergoes circular motion, what is the equation determining its radius r_0 ?

- A. $\frac{l^2}{mr_0} = kar_0 e^{-ar_0}$ B. $\frac{l^2}{mr_0} = ke^{-ar_0}(1 + ar_0)$ ✓ C. $\frac{l^2}{2mr_0} = kar_0 e^{-ar_0}$ D. $\frac{l^2}{2mr_0} = ke^{-ar_0}(1 + ar_0)$

10. Calculate the collector current and determine whether or not the transistor in figure shown below is in saturation. Assume $V_{CE}(sat) = 0.2V$

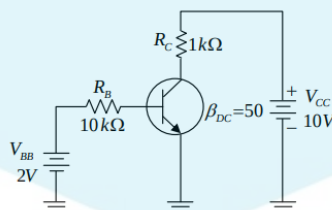

- A. $6.5mA$, not in saturation ✓
 B. $11.5mA$, in saturation
 C. $11.5mA$, not in saturation

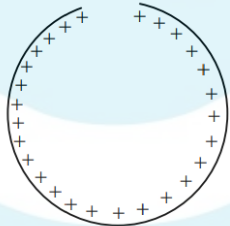
- D. $6.5mA$, in saturation
11. Charges are placed as follows: q at $(a,a,0)$ and $(-a,-a,0)$ and $-q$ at $(-a,a,0)$ and $(a,-a,0)$. At large distances, how does the electrostatic potential behave as a function of the distance r from the center $(0,0,0)$?
 $1/r^3$ ✓ $1/r^2$ $1/r$ $1/r^4$
12. An $n \times n$ Hermitian matrix A is not a multiple of the identity matrix. Which one of the following statements is always true?
A. $nTr(A^2) = (TrA)^2$
B. $nTr(A^2) < (TrA)^2$
C. $nTr(A^2) > (TrA)^2$ ✓
D. $Tr(A^2) = n(TrA)^2$
13. A ring of radius $0.5m$ has a gap of $0.002\pi m$. If the ring carries a charge of $\pm 1.0C$ distributed uniformly along it, then the electric field at the centre of the ring is
A. $7.5 \times 10^7 NC^{-1}$ B. $7.2 \times 10^7 NC^{-1}$ ✓ C. $6.2 \times 10^7 NC^{-1}$ D. $6.5 \times 10^7 NC^{-1}$
- 
14. Consider a system of two particles at temperature $T \rightarrow \infty$. Each of them can occupy three different quantum energy levels having energies $0, \epsilon$ and 2ϵ , and both of them cannot occupy the same energy level. What is the average energy of the system?
A. ϵ B. $\frac{3\epsilon}{2}$ C. 2ϵ ✓ D. 4ϵ
15. If x and y have the joint probability distribution $f(x,y) = \frac{3}{4} + xy$ for $0 < x,y < 1$, and $f(x,y)=0, 0$ otherwise. What is the probability that y assumes a value greater than $\frac{1}{2}$ given that x is equal to $\frac{1}{2}$?
A. $\frac{6}{16}$ B. $\frac{7}{16}$ C. $\frac{8}{16}$ D. $\frac{9}{16}$ ✓

16. The wave function of an electron in one dimension is given by

$$\psi(x) = \begin{cases} 0 & x < 0 \\ 2\sqrt{3}e^{-x}(1 - e^{-x}) & x \geq 0 \end{cases}$$

The ratio between the expected position $\langle x \rangle$ and the most probable position x_m is

A. 0.856 B. 1.563 ✓ C. 2.784 D. 3.567

17. A particle is to slide along the horizontal circular path on the inner surface of the funnel as shown in the figure. The surface of the funnel is frictionless. What must be the speed of the particle (in terms of r and θ) if it is to execute this motion?

A. $\sqrt{rg\sin\theta}$ B. $\sqrt{rg\cos\theta}$ C. $\sqrt{rg\tan\theta}$ D. $\sqrt{rg\cot\theta}$ ✓

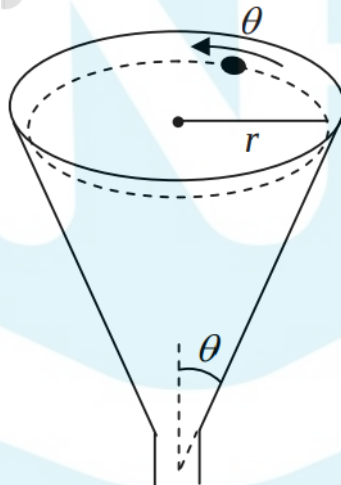

18. Two rails of a railroad track are insulated from each other and from the ground and are connected by a milli-voltmeter. What is the reading of the milli-voltmeter when a train travels at the speed 90km/hr down the track? Assume that the vertical component of the earth's magnetic field is 0.2 gauss and that the tracks are separated by two meters. Use $1 \text{ gauss} = 10^{-4} \text{ Tesla} = 10^{-4} \text{ V.sec/m}^2$

A. 10
B. 1 ✓
C. 0.2
D. 180

19. A particle of mass m moves in a one-dimensional potential $V(x) = F|x_0|$, where F_0 is a positive constant. Given the initial conditions, $x(0) = x_0 > 0$ and $\dot{x}(0) = 0$, which one of the following statements is correct?
- A. The particle undergoes simple harmonic motion about the origin with frequency $\omega = 2\pi\sqrt{\frac{F_0}{mx_0}}$
- B. The angular frequency of oscillations of the particle is $\omega = \frac{\pi}{2}\sqrt{\frac{F_0}{2mx_0}}$ ✓
- C. The particle begins from rest and is accelerated along the positive x -axis such that $x(t) = \frac{x_0 + F_0 t^2}{2m}$
- D. The angular frequency of oscillations of the particle is independent of its mass
20. A carbon rod of resistance R_c and a metal rod of resistance R_m are connected in series. Let their linear temperature coefficients of resistivity have magnitudes α_c and α_m , respectively. The condition that the net resistance would be independent of temperature is
- A. $R_c = R_m$ B. $\alpha_c = \alpha_m$ C. $\frac{R_c}{R_m} = \frac{\alpha_m}{\alpha_c}$ ✓ D. $\frac{R_m}{R_c} = \frac{\alpha_m}{\alpha_c}$
21. The 2's compliment of 1111 1111 is
- A. 00000001 ✓ B. 00000000 C. 1111 1111 D. 1000 0000
22. Two tuning forks A and B are struck instantaneously to obtain Lissajous figures. The figures go through a complete cycle in 20 s. Fork A is loaded with wax, so the cycle period changes to 10 s. If the frequency of fork B is 256.10 Hz, what is the frequency of fork A after loading?
- A. 256.00 Hz ✓ B. 256.05 Hz C. 256.15 Hz D. 256.20 Hz
23. Consider a classical harmonic oscillator in thermal equilibrium at a temperature T . If the spring constant is changed to twice its value isothermally, then the amount of work done on the system is
- A. $K_B T \ln 2$ B. $K_B T \frac{\ln 2}{2}$ ✓ C. $2K_B T \ln 2$ D. $-K_B T \ln 2$
24. The solution of the differential equation $y'' - 2y' - 3y = e^u$ is given as $C_1 e^{-t} + C_2 e^{2t} + C_3 e^{3t}$. The values of the coefficients C_1, C_2 and C_3 are:
- A. C_1, C_2 and C_3 are arbitrary
- B. C_1, C_3 and $C_2 = \frac{-1}{3}$ ✓

- C. C_2, C_3 and $C_1 = \frac{-1}{3}$
D. C_1, C_2 and $C_3 = \frac{-1}{3}$

25. A free particle of energy E , characterized by a plane wave of wavelength λ enters a region of constant potential $-V$ (where $E > V > 0$). Within the region of the potential, the wavelength of the particle is $\frac{\lambda}{2}$. The ratio $\frac{V}{E}$ is:
A. $\frac{-1}{3}$ B. -3 C. 3 ✓ D. $\frac{1}{3}$



Part B: 3 mark questions

1. Consider a quantum particle of mass m moving in potential

$$V(x,y) = \begin{cases} \frac{1}{2}m\omega^2(x^2 + y^2) & x > 0, y > 0 \\ \infty & \text{otherwise} \end{cases}$$

what is the degeneracy of the energy state $9\hbar\omega$, where $\omega > 0$ measures the strength of the potential?

- A. 4 ✓ B. 2 C. 10 D. 5
2. Consider a particle with total energy E is oscillating in a potential $U(x) = A|x|^n$ with $A > 0$ and $n > 0$ in one dimension. Which one of the following gives the relation between the time period of oscillation T and the total energy E :
A. $T \propto E^{\frac{1}{n}-\frac{1}{2}}$ ✓ B. $T \propto E^0$ C. $T \propto E^n$ D. $T \propto E^{\frac{1}{n}}$
3. A classical gas of N particles is kept at a temperature T and is confined to move on a two-dimensional surface (XY -plane). If an external linear force field is applied along the x -axis, then the partition function of the system will be proportional to
A. T^N B. T^{2N} C. $T^{\frac{N}{2}}$ D. $T^{\frac{3N}{2}}$ ✓

4. An electromagnetic field is given by

$$\vec{E}(\vec{r}, t) = -\frac{1}{4\pi\epsilon_0} \frac{q}{r^2} \theta(vt - r) \hat{r}, \quad \vec{B}(\vec{r}, t) = 0$$

$$\theta(x) = \begin{cases} 1 & x > 0 \\ 0 & x \leq 0 \end{cases}$$

The corresponding charge density ρ and current density \vec{J} are given by

- A. $\rho = -q\delta^3(\vec{r})\theta(vt - r) + \frac{q}{4\pi r^2}\delta(vt - r)$; $\vec{J} = 0$
B. $\rho = -q\delta^3(\vec{r})\theta(vt - r)$; $\vec{J} = 0$
C. $\rho = \frac{q}{4\pi r^2}\delta(vt - r)$; $\vec{J} = \frac{qv}{4\pi r^2}\delta(vt - r)\hat{r}$
D. $\rho = -q\delta^3(\vec{r})\theta(vt - r) + \frac{q}{4\pi r^2}\delta(vt - r)$; $\vec{J} = \frac{qv}{4\pi r^2}\delta(vt - r)\hat{r}$ ✓
5. A particle of mass m is placed in a potential well $U(x) = cx^n$, where c is a positive constant and n is an even positive integer. If the particle is in equilibrium at constant temperature, which one of the following relations between average kinetic energy

$\langle K \rangle$ and average potential energy $\langle U \rangle$ is correct?

- A. $\langle K \rangle = \frac{2}{n} \langle U \rangle$ B. $\langle K \rangle = \langle U \rangle$ C. $\langle K \rangle = \frac{n}{2} \langle U \rangle$ ✓ D. $\langle K \rangle = 2 \langle U \rangle$

6. What is the charge stored on each capacitor C_1 and C_2 in the circuit shown in the given figure?

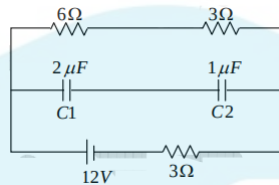

- A. $6\mu C, 6\mu C$ ✓
 B. $6\mu C, 3\mu C$
 C. $3\mu C, 6\mu C$
 D. $3\mu C, 3\mu C$

7. A particle moving in two dimensions satisfies the equations of motion

$$\dot{x}(t) = x(t) + y(t)$$

$$\dot{y}(t) = x(t) - y(t)$$

with $\dot{x}(0) = 0$. What is the value of $\frac{x(\infty)}{y(\infty)}$?

- A. $1 - \frac{1}{\sqrt{2}}$ B. $1 + \frac{1}{\sqrt{2}}$ C. $\sqrt{2} - 1$ D. $\sqrt{2} + 1$ ✓

8. Analyse the common emitter transistor circuit given in the figure. If the current gain (β) increases by 50%, the relative change in collector current (I_C) is approximately

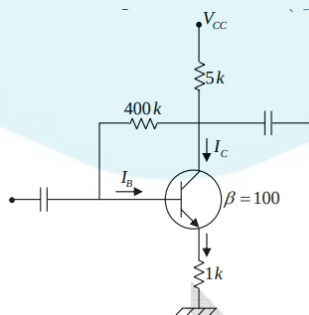

- A. 5%

- B. 15% ✓
 C. 20%
 D. 25%

9. Consider a cube (see figure) of volume V containing N molecules each of mass m with uniform density $n = \frac{N}{V}$. Suppose this system is equivalent to a system of M non-interacting gases such that molecules of the i -th gas are $N_i = n_i V$ in number, each with an identical y -component of velocity v_i . What is the pressure P on the surface ABCD of area A ?

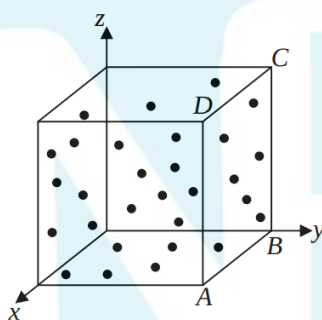

- A. $P = m \sum_{i=1}^M n_i v_i^2$ ✓
 B. $P = \frac{m \sum_{i=1}^M n_i v_i^2}{\sum_{i=1}^M n_i}$
 C. $P = \frac{m \sum_{i=1}^M n_i v_i^2}{2}$
 D. $P = 2m \sum_{i=1}^M n_i v_i^2$

10. What is the value of the following contour integral I taken counterclockwise around the circle $|z| = 2$?

$$I = \oint_C \frac{dz}{z^3(z+4)}$$

- A. $\frac{\pi i}{2}$ B. $\frac{\pi i}{32}$ ✓ C. $\frac{\pi i}{16}$ D. $\frac{\pi i}{4}$

11. The wave function of a particle subjected to a spherically symmetric potential $V(r)$ is given by $\psi(\vec{r}) = (x - y + 2z)f(r)$. Which one of the following statements is true about $\psi(\vec{r})$?

- A. It is an eigenfunction of \vec{L}^2 with $l = 0$
 B. It is an eigenfunction of \vec{L}^2 with $l = 1$ ✓
 C. It is an eigenfunction of \vec{L}^2 with $l = 2$

- D. It is not an eigenfunction of \vec{L}^2
12. The Hamiltonian for a particle of mass m is given by $H = \frac{(p-\alpha q)^2}{2m}$, where α is a nonzero constant. Which one of the following equations is correct?
- A. $p = m\dot{q}$
B. $\alpha\dot{p} = \dot{q}$
C. $\ddot{q} = 0$ ✓
D. $L = \frac{1}{2}m\dot{q}^2 - \alpha q\dot{q}$
13. A continuous He-Ne laser beam ($\lambda = 632.8nm$) is 'chopped', using a spinning aperture into $1\mu s$ square pulses. The order-of-magnitude estimate of the spectral width $\Delta\lambda$ of the emerging 'pulsed' light is
- A. $10^{-9}m$
B. $10^{-12}m$
C. $10^{-15}m$ ✓
D. $10^{-18}m$
14. The Hamiltonian of a classical particle is given by $H(p, q) = \frac{p^2}{2m} + \frac{kq^2}{2}$. Given $F(p, q, t) = \ln(p + im\omega q) - i\alpha\omega t$ is a constant of motion (where $\omega = \sqrt{\frac{k}{m}}$). What is the value of α ?
- A. 2π
B. 0
C. 1 ✓
D. 1π
15. Three polarizers are stacked, normal to a central axis, along which is incident a beam of unpolarized light of intensity I_0 . The first and the third polarizers are perpendicular to each other and the middle polarizer is rotated at an angular frequency ω about the central axis (light beam). The time-dependent intensity of light emerging after the third polarizer will be given by
- A. $(\frac{I_0}{16})[1 - \cos(4\omega t)]$ ✓
B. $(\frac{I_0}{8})[1 - \cos(2\omega t)]$

C. $\left(\frac{I_0}{4}\right)[1 - 2\cos\omega t]$

D. $\left(\frac{I_0}{16}\right)[1 - \cos^2\omega t]$



Part C: 3 mark question

1. A thin film of water having refractive index $n = 1.333$ floats on the surface of a beaker of silicone oil having a refractive index of $n_s = 1.40$. The arrangement is illuminated by 600nm light incident normally from the top and a large region of the film appears bright red. What is the minimum possible thickness of the film (in nm)?

ANS: 0225

2. What is the value of the following integral?

$$I = \frac{100\sqrt{2}}{\pi} \int_0^{\pi/2} x \delta(2\sin x - \sqrt{2}) dx$$

ANS: 0025

3. Two compartments in a cylinder with a uniform cross-section and a total length of 102cm are separated by a sliding partition which can move but does not allow heat to pass across it. No molecules are present in either of the compartments. The radiation inside each compartment is in thermal equilibrium with its walls. The walls at the two ends of the cylinder are maintained at temperatures of 2000K and 4000K, respectively. The sides are perfectly insulated. Find the location of the partition, measured from the left end of the container.

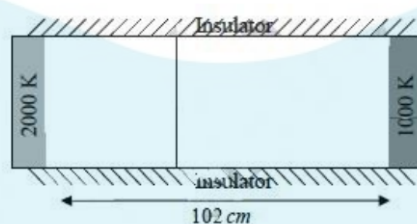

ANS: 0006

4. A laser has output power of 150mW with beam diameter of 2mm at a wavelength 630nm . What is the value of the electric field in units of V m/ is? Use Coulomb's constant $\frac{1}{4\pi\epsilon_0} = 9 \times 10^9 Nm^2C^{-2}$
- ANS: 6000
5. A two-state quantum system has energy eigenvalues $\pm\epsilon$ corresponding to normalised states ψ_{\pm} . At time $t = 0$ the system is in the quantum state $\frac{[\psi_+ + \psi_-]}{\sqrt{2}}$. Find the

$10000 \times$ probability that the system will be in the same state at time $t = \frac{h}{6\epsilon}$, where h is the Planck's constant.

ANS: 2500

6. A small insect of mass m is sitting on the rim of a uniform circular horizontal disk of radius R and mass M . The system is rotating at a constant angular velocity ω_i about a frictionless vertical axis passing through the centre of the disk. The insect started to crawl towards the centre of the disk. Assume $\frac{M}{m} = 10$, and let the final angular velocity of the system, when the insect reaches the centre of the disk be ω_f . What is the value of $\frac{100\omega_i}{\omega_f}$

ANS: 0120

7. A particle is moving on a one-dimensional discrete lattice with lattice spacing unity. It can move from a site to its nearest neighbour site every $1/5$ seconds with p being the probability to move right and $q = (1 - p)$ being the probability to move left. Consider that the particle starts at origin, $x = 0$ at time $t = 0$. Taking $p = \frac{3}{4}$, calculate the variance at time $t = 5 \times 10^4$ seconds, where $\langle x \rangle$ is the average position.

ANS: 46875

8. Analyse the op-amp circuit shown in the figure below. What is the output voltage V_0 in millivolts if $V_1 = 2.5V$ and $V_2 = 2.25V$?

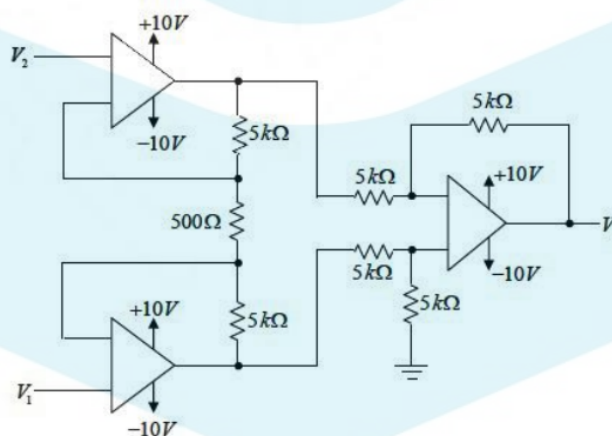

ANS: : 5305

9. Some bacteria are added to a bucket at time 10 am. The number of bacteria doubles every minute and reaches a number 16×10^{15} at 10 :18 am. How many seconds

after 10 am were there 25×10^{13} bacteria?

ANS: 0720

10. A cleaning machine presses a circular mop of radius $R = 30\text{cm}$ vertically down on a floor with a total force $F = 25\text{N}$ and rotates it with a constant angular speed about the vertical axis passing through the centre of mop. If the force is distributed uniformly over the mop and if the coefficient of friction between the mop and the floor is $\mu = 0.25$, what is the value of torque in N - cm applied by the machine on the mop?

ANS: 0125