



Nitesh Physics

**JEST 2022
PHYSICS**



An Institute of
NET-JRE, IIT-JAM, GATE, JEST, TIFR
CUET Entrance in Physics
Physical Sciences
New Delhi

September 25, 2022

Part A: 1 mark Questions

- For a system of unit mass, the dynamical variables follow the relation $\dot{x}^2 = kx_0^2 + \dot{x}_0^2 - kx^2$ where, x is the position of the system at time t , and x_0 is its initial position. What is the force acting on the system?

A. $-kx$ ✓ B. $-k(x - x_0)$ C. $-\frac{1}{2}k(x - x_0)$ D. $\frac{1}{2}k(x - x_0)^2$
- The probability that you get a sum m from a throw of two identical fair dice is P_m . If the dice have 6 (six) faces labelled by 1, 2, . . . 6, which of the following statements is correct?

A. $P_9 = P_5$ ✓ B. $P_9 = P_4$ C. $P_9 = P_3$ D. $P_9 = P_6$
- A particle of mass m is moving in a circular path of constant radius r such that its centripetal acceleration a_c is varying with time t as $a_c = k^2 r t^2$ where k is a constant. The power delivered to the particle by the force acting on it is

A. $mk^2 r^2 t$ ✓ B. $2mk^{\frac{3}{2}} r^2$ C. $\frac{1}{2}mk^2 r^2 t$ D. 0
- The front-end of a train moving with constant acceleration, passes a pole with velocity u , and its back-end passes the pole with velocity v . With what velocity does the mid-point of this train pass the same pole?

A. $\sqrt{\frac{u^2 + v^2}{2}}$ ✓
 B. $\frac{1}{2}\sqrt{u^2 + v^2}$
 C. $\frac{uv}{u+v}$
 D. $\frac{u+v}{2}$
- A system with two energy levels is in thermal equilibrium with a heat reservoir at a temperature of 600 K. The energy gap between the levels is 0.1 eV. Let p be the probability that the system is in a higher energy level. Which of the following the statement is correct? [Note : 1 eV = 11600 K]

A. $0.1 < p \leq 0.2$ ✓ B. $0 < p \leq 0.1$ C. $0.2 < p \leq 0.3$ D. $p \geq 0.2$
- If mean and standard deviation of the energy distribution of an equilibrium system vary with temperature T as T^ν and T^α respectively, then ν and α must satisfy

A. $\nu + 1 = 2\alpha$ ✓ B. $2\nu + 12\alpha$ C. $\nu = 1 + 2\alpha$ D. $2\nu = 1 + \alpha$
- Adding 1 eV of energy to a large system did not change its temperature (27°C) whereas it changed the number of micro-states by a factor of r . r is of the order [Note: 1 eV = 11600 K]

A. 10^{17} ✓ B. 10^{23} C. 10^4 D. 10^{-19}

8. The ratio of specific heat of electrons in a heated copper wire at two temperatures 200°C and 100°C is
 A. 1.27 ✓ B. 2 C. 1.41 D. 1.61
9. A conducting sphere of radius R is placed in a uniform electric field E_0 directed along $+z$ axis. The electric potential for outside points is given by $V_{out} = -E_0(1 - (R/r)^3)r\cos\theta$, where r is the distance from the centre and θ is the polar angle. The charge density on the surface of the sphere is
 A. $3\epsilon_0 E_0 \cos\theta$ ✓ B. $\epsilon_0 E_0 \cos\theta$ C. $-3\epsilon_0 E_0 \cos\theta$ D. $\frac{1}{3}\epsilon_0 E_0 \cos\theta$
10. A point charge q is kept d distance above an infinite conducting plane. What is the energy stored in the configuration?
 A. $\frac{-1}{4\pi\epsilon} \frac{q^2}{4d}$ ✓ B. $\frac{-1}{4\pi\epsilon} \frac{q^2}{2d}$ C. $\frac{1}{4\pi\epsilon} \frac{q^2}{2d}$ D. $\frac{1}{4\pi\epsilon} \frac{q^2}{4d}$
11. Two point charges $2q$ and q are placed inside two spherical cavities of equal radii $R/4$ in a solid conducting sphere of radius R , as shown in the figure. The cavities are placed along a diagonal at distances $R/2$ from the center of the solid sphere. The electrical potential at a point P , $3R/2$ distance away from the center along the same diagonal, is given by

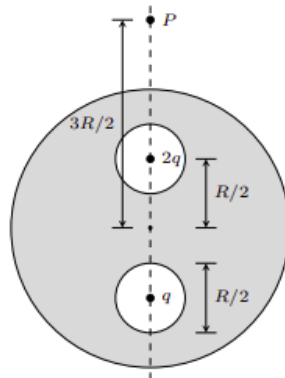

- A. $\frac{1}{4\pi\epsilon} \frac{2q}{R}$ ✓
 B. $\frac{1}{4\pi\epsilon} \frac{5q}{R}$
 C. 0
 D. $\frac{1}{4\pi\epsilon} \frac{3q}{R}$

12. If θ and ϕ are respectively the polar and azimuthal angles on the unit sphere, what is $\langle \cos^2(\theta) \rangle$ and $\langle \sin^2(\theta) \rangle$, where $\langle O \rangle$ denotes the average of O ?

- A. $\langle \cos^2(\theta) \rangle = 1/3, \langle \sin^2(\theta) \rangle = 2/3$ ✓
- B. $\langle \cos^2(\theta) \rangle = 1/2, \langle \sin^2(\theta) \rangle = 1/2$
- C. $\langle \cos^2(\theta) \rangle = 3/4, \langle \sin^2(\theta) \rangle = 1/4$
- D. $\langle \cos^2(\theta) \rangle = 2/3, \langle \sin^2(\theta) \rangle = 1/3$

13. The function $f(x)$ shown below has non-zero values only in the range $0 < x < a$. Which of the

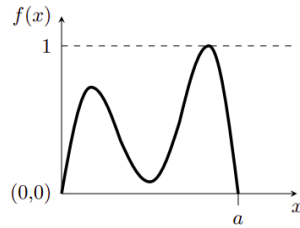

following figure represents $f(3x)$?

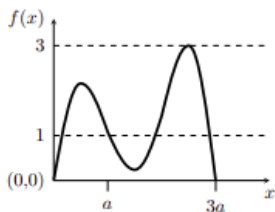
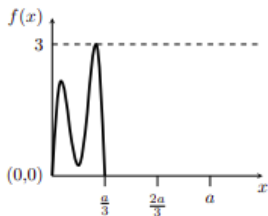
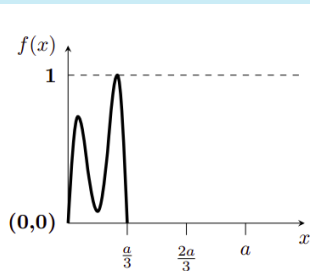

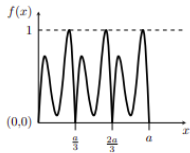

D.

14. Consider a complex function

$$f(z) = \frac{1}{6z^2 + 3z^2 + 2z + 1}$$

. What is the sum of the residues at its poles?

- A. 0 ✓ B. $\frac{4}{7}$ C. $\frac{2}{7}$ D. $\frac{i\sqrt{3}}{7}$

15. Consider a complex number $z = x + iy$. Where do all the zeros of $\cos(z)$ lie?

- A. On the $y = 0$ line. ✓ B. On the $x = 0$ line. C. On the $x = y$ line. D. On the $x = -y$ line.

16. Two identical simple pendula of length L are connected by a spring at a height of $L/2$ as shown in the figure. Assuming the spring constant is mg/L , where m is the mass of the bob and g is the acceleration due to gravity, what is the ratio of the highest to lowest eigen-frequencies of the system?

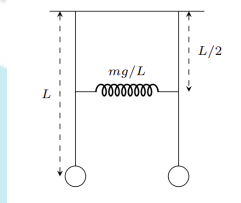

- A. $\sqrt{\frac{3}{2}}$ ✓ B. 1 C. $\sqrt{2}$ D. $\sqrt{3}$

17. The wavefunction of the electron in a Hydrogen atom in a particular state is given by $\pi^{-1/2} a_0^{-3/2} \exp(-r/a_0)$. Which of the following figures qualitatively depicts the probability ($P(r)$) of the electron to be within a distance r from the nucleus?

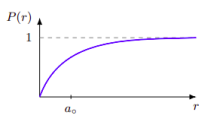

A. ✓

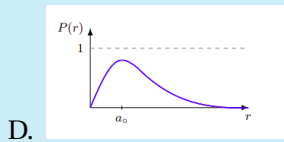
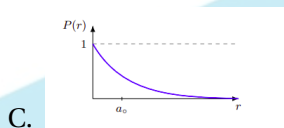
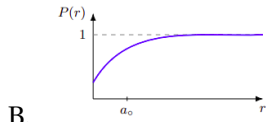

18. A thin film surrounded by air has an index of refraction of 1.4. A region of the film appears bright blue ($\lambda = 400 \text{ nm}$) when white light is incident perpendicular to the surface. What might be the minimum thickness of the film?
 A. 140 nm B. 280 nm C. 420 nm D. 70 nm ✓
19. The trajectory of a particle which undergoes simple harmonic motion on a plane is shown in the figure. The ratio of the frequencies for the motion along x and y directions is given by
 A. $\frac{3}{5}$ ✓ B. $\frac{2}{3}$ C. $\frac{3}{2}$ D. $\frac{4}{5}$

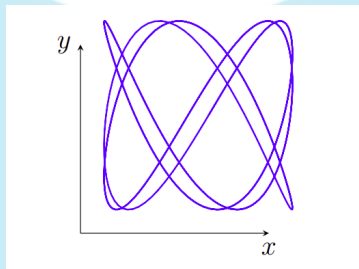

20. The base current in the first transistor of the following circuit having two identical Silicon-based npn transistors of β value 100, is closest to
 A. $3.6 \mu\text{A}$ ✓ B. 0.36 mA C. 5.0 mA D. $5.0 \mu\text{A}$
21. An ideal diatomic gas at pressure P is adiabatically compressed so that its volume becomes $\frac{1}{n}$ times the initial value. The final pressure of the gas will be
 A. $n^{\frac{7}{5}}P$ ✓ B. $n^{\frac{7}{2}}P$ C. $n^{\frac{7}{5}}P$ D. $n^{\frac{5}{3}}P$

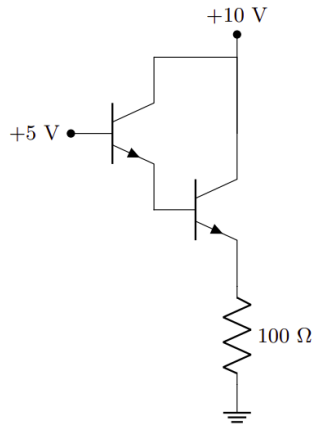

22. A beam of high energy neutrons is scattered from a metal lattice, where the spacing between nuclei is around 0.4 nm. In order to see quantum diffraction effects, the kinetic energy of the neutrons must be of the order [Mass of neutron = $1.67 \times 10^{-27} \text{ kg}$, Planck's constant = $6.62 \times 10^{-34} \text{ m}^2 \text{ kg s}^{-1}$]
- A. meV ✓ B. MeV C. eV D. keV
23. Consider eight electrons confined in a 1D box of length d. What is the minimum total energy for the system allowed by Pauli's exclusion principle?
- A. $\frac{15h^2}{2md^2}$ ✓ B. $\frac{15h^2}{4md^2}$ C. $\frac{30h^2}{md^2}$ D. $\frac{15h^2}{8md^2}$
24. Consider 5 identical spin $\frac{1}{2}$ particles moving in a 3-dimensional harmonic oscillator potential,

$$V(r) = \frac{1}{2} m \omega^2 r^2 = \frac{1}{2} m \omega^2 (x^2 + y^2 + z^2)$$

The degeneracy of the ground state of the system is

- A. 20 ✓ B. 7 C. 5 D. 32
25. A particle is confined in an infinite potential well of the form given below

$$V(x) = \begin{cases} 4V_0 x(1-x), & \forall \quad 0 \leq x \leq 1 \\ \infty, & \text{otherwise} \end{cases}$$

If the particle has energy $E \geq V_0$, which of the following could be the form of its wavefunction?

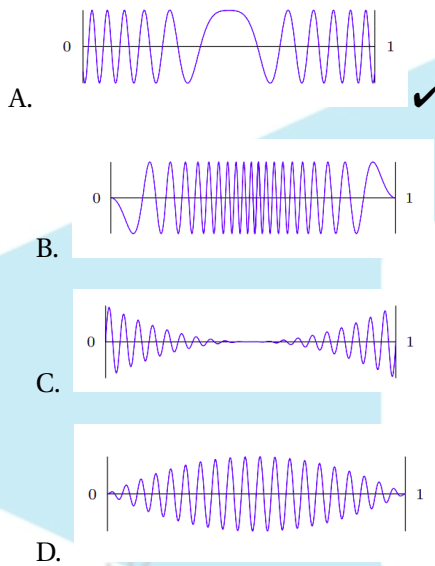

Part B: 3 mark questions

1. A cylinder of radius R is constrained to roll without slipping on a horizontal plane under the action of a constant force F applied at distance d above the axis of the cylinder. In the process, it experiences a frictional force f at the point of contact (see figure). For what value of d , the magnitude of f is minimum?

- A. $R/2$ ✓ B. R C. $-R/2$ D. $-R$

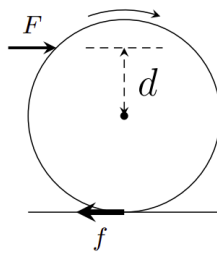

2. A small object A of mass m is free to slide on the inclined plane of a triangular block B of mass $2m$ (see figure). Initially both the blocks are motionless. Block A starts sliding under the action of gravity from the highest point of block B. What is the speed of block B, when block A hits the floor?

- A. $\frac{1}{3}\sqrt{gL}$ ✓ B. $\frac{1}{2}\sqrt{gL}$ C. \sqrt{gL} D. $\frac{2}{3}\sqrt{gL}$

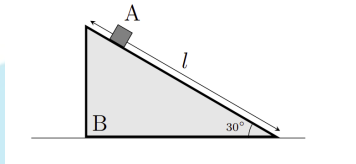

3. A particle moving in a central force field centered at $r = 0$, follows a trajectory given by $r = e^{-\alpha\theta}$ where, (r, θ) is the polar coordinate of the particle and $\alpha > 0$ is a constant. The magnitude of the force is proportional to
 A. r^{-3} ✓ B. r^2 C. r^{-1} D. r^3
4. For a one dimensional simple harmonic oscillator, for which $|0\rangle$ denotes the ground state, what is the constant β in

$$\langle 0|e^{ikx}|0\rangle = e^{-\beta\langle 0|e^{x^2}|0\rangle}$$

- A. $\beta = \frac{k^2}{2}$ ✓ B. $\beta = k^2$ C. $\beta = \frac{k^2}{4}$ D. $\beta = 2k^2$
5. A particle of mass m moves in one dimension. The exact eigenfunction for the ground state of the system is

$$\psi(x) = \frac{A}{\cos(\lambda x)}$$

where, λ is a constant and A is the normalization constant. If the potential $V(x)$ vanishes at infinity, the ground state energy of the system is

- A. $-\frac{\hbar^2\lambda^2}{2m}$ ✓ B. $\frac{\hbar^2\lambda^2}{2m}$ C. $\frac{\hbar^2\lambda}{2m}$ D. $-\frac{\hbar^2\lambda}{2m}$
6. The Lagrangian of a particle of unit mass is given by $L = \frac{1}{2}(\dot{x}^2 - x^2 = 2x\dot{x})$. The Hamiltonian of this system is given by//
 A. $\frac{1}{2}p^2 - px + x^2$ ✓
 B. $\frac{1}{2}(p^2 + x^2)$
 C. $\frac{1}{2}(p - x)^2$
 D. $\frac{1}{2}p^2 + px - x^2$
7. The energy of two Ising spins ($s_1 = \pm 1, s_2 = \pm 1$) is given by $E = s_1 s_2 \frac{1}{2}(s_1 + s_2)$. At certain temperature T probability that both spins take $+1$ values is 4 times than they both take -1 values. What is the probability that they have opposite spins? [$\beta = 1/K_B T$]
 A. $1/6$ B. $e^\beta \tanh\beta$ C. $\frac{e^\beta}{1+e^{2\beta}}$ D. $1/2$
8. A point charge q is fixed at point A inside a hollow grounded conducting spherical shell of radius R , at a distance a from the center C . The force on the sphere due to the presence of

the point charge is

- A. $\frac{1}{4\pi\epsilon} \frac{q^2 aR}{(R+a)^2(R-a)^2}$ in magnitude and along \vec{AC} ✓
- B. $\frac{1}{4\pi\epsilon} \frac{q^2 aR}{(R+a)^2(R-a)^2}$ in magnitude and along \vec{CA}
- C. $\frac{1}{4\pi\epsilon} \frac{q^2}{(R-a)^2}$ in magnitude and along \vec{AC}
- D. $\frac{1}{4\pi\epsilon} \frac{q^2}{(R-a)^2}$ in magnitude and along \vec{CA}

9. A rectangular dielectric slab partly fills two identical rectangular parallel plate capacitors which are maintained at potentials V_1 and V_2 with $V_1 > V_2$. The slab can freely move in the space between the capacitor plates without any friction. Which of the following is true?

- A. The slab will move towards higher potential. ✓
- B. The slab will move towards lower potential.
- C. The slab will not move.
- D. The slab will position itself at $1/V_1 : 1/V_2$ ratio between capacitors 1 and 2.

10. $G = e, a, a^2, b, ba, ba^2$ is a group of order 6. e is the identity element and a is of order 3. What could be the order of the element b ?

- A. 2 ✓
- B. 3
- C. 1
- D. Can't be determined

11. Consider the differential operators given below:

$$J^+ = x^2 \frac{d}{dx} + \mu x, J^0 = x \frac{d}{dx} + \rho$$

that act on the set of monomials x^m . Here, μ and ρ are constants. Which one the following is equal to $(J^0 J^+ - J^+ J^0)x^m$?

- A. $J^+ x^m$ ✓
- B. $mJ^+ x^{(m-1)}$
- C. $-(m+1)J^+ x^{(m-1)}$
- D. $-J^+ x^m$

12. If three real variables x, y and z evolve with time t following

$$\frac{dx}{dt} = x(y-z), \frac{dy}{dt} = y(z-x), \frac{dz}{dt} = z(x-y)$$

then which of the following quantities remains invariant in time ?

- A. $\frac{1}{xy} + \frac{1}{yz} + \frac{1}{xz}$
- B. $x^2 + y^2 + z^2$
- C. $xy + yz + zx$
- D. $\frac{1}{x} + \frac{1}{y} + \frac{1}{z}$

13. A circularly polarized laser of power P is incident on a particle of mass m . The particle, which was initially at rest, completely absorbs the incident radiation. The kinetic energy of the particle as a function of time t is given by

- A. $\frac{1}{2}Pt \left(\frac{Pt}{mc^2} + 1 \right)$ ✓
- B. $\frac{1}{2}Pt \left(\frac{Pt}{mc^2} - 1 \right)$
- C. $\frac{P^2 t^2}{2mc^2}$
- D. $\frac{Pt}{2}$

14. What is the output voltage of the following circuit for the input current 1 nA?

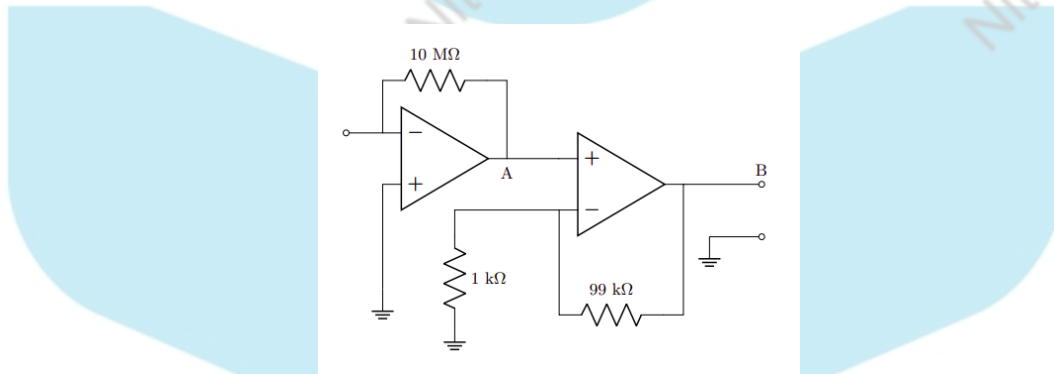

- A. 1V ✓
- B. 1mV
- C. 1μV
- D. 1nV

15. A container has two compartments. One compartment contains Oxygen gas at pressure P_1 , volume V_1 and temperature T_1 . The second compartment contains Nitrogen gas at pressure

P_2 , volume V_2 , and temperature T_2 . The partition separating two compartments is removed and the gases are allowed to mix. What is the temperature of the mixture when it comes to equilibrium?

- A. $\frac{(P_1 V_1 + P_2 V_2) T_1 T_2}{P_1 V_1 T_2 + P_2 V_2 T_1}$
B. $\frac{V_1 T_1 + V_2 T_2}{V_1 + V_2}$
C. $\frac{P_1 V_1 T_2 + P_2 V_2 T_1}{P_1 V_1 + P_2 V_2}$
D. $\frac{P_1 V_1 T_1 + P_2 V_2 T_2}{P_1 V_1 + P_2 V_2}$

Part C: 3 mark question

- Two uniform rods of length 1 m are connected to a friction-less hinge A. The hinge is held at a height and the other ends of the rods rests on a friction-less plane, such that the angle between the rods is $2\pi/3$. If the hinge is released from the rest, what is the speed of the hinge when it hits the floor? [Acceleration due to gravity is 9.81ms^{-2}]

ANS: 1.92

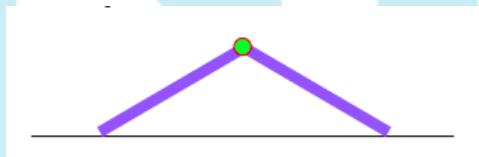

- A pair of crossed ideal linear polarizers allow no light to pass through. To produce some output one can insert optical elements between the crossed polarizers. For given light beam of input intensity I_0 , Nirmalya inserts a quarter-wave plate between the crossed polarizers and records an output intensity αI_0 . On the other hand, Ayan inserts two linear polarizers having orientations 30° and 60° w.r.t. the first polarizer of the crossed pair, and records an output intensity of βI_0 . What is the ratio $\frac{\alpha}{\beta}$?

ANS: 1.19

- Optical excitation of intrinsic germanium creates an average density of 10^{12} conduction electrons per cm^3 in the material at liquid nitrogen temperature. At this temperature, the electron and hole mobilities are equal, $\mu = 0.5 \times 10^4 \text{m}^2 \text{V}^{-1} \text{s}^{-1}$. The germanium dielectric constant is 20. If 100 Volts is applied across 1 cm cube of crystal under these condition, about how much current, in mA, is observed?[Charge of electron = $1.6 \times 10^{19} \text{C}$]

ANS: 1600000

- A particle can access only three energy levels $E_1 = 1 \text{eV}$, $E_2 = 2 \text{eV}$, and $E_3 = 6\text{eV}$. The average energy $\langle E \rangle$ of the particle changes as temperature T changes. What is the ratio of the minimum to the maximum average energy of the particle ?

ANS: 0.33

- A system of N classical non-identical particles moving in one dimensional space is governed by the Hamiltonian

$$H = \sum_{i=1}^N (A_i p_i^2 + B_i |q_i|^\alpha)$$

where p_i and q_i are momentum and position of the i-th particle, respectively, and the

constant parameters A_i and B_i characterize the individual particles. When the system is in equilibrium at temperature T , then the internal energy is found to be $E = \langle H \rangle = \frac{2}{3} N k_B T$, where k_B is the Boltzmann constant. What is the value of α ?

ANS: 6.0

6. An electron of kinetic energy 100 MeV moving in a region of uniform magnetic field penetrates a layer of lead. In the process it loses half of its kinetic energy. The radius of curvature of the path has changed by a factor

ANS: 0.50

7. Let $M = 2I + \sigma_x + i\sigma_y + \sigma_z$ is a 2×2 square matrix, where, σ_α denotes α^{th} Pauli matrix, and I denotes the 2×2 identity matrix. It is given that $|u\rangle = \begin{pmatrix} 1 \\ 0 \end{pmatrix}$ and $|v\rangle = \begin{pmatrix} 1 \\ -1 \end{pmatrix}$ are column vectors. What is the value of $\langle u | \sqrt{M} | v \rangle$?

ANS: 0.50

8. The frequency dispersion relation of the surface waves of a fluid of density ρ and temperature T , is given by $\omega^2 = gk + Tk^3/\rho$, where ω and k are the angular frequency and wave-number, respectively, g is the acceleration due to gravity. The first term in r.h.s. describes the gravity waves and the second term describes the surface tension wave. What is the ratio of the first term to the second term, when the phase velocity is equal to the group velocity?

ANS: 1.00

9. A 12-bit analog-to-digital converter has an operating range of 0 to 1 V. The smallest voltage step (in mV, upto two significant digits) that one can record using this converter is

ANS: 0.24

10. One mole of an ideal gas undergoes a thermodynamic cycle formed by an isobaric process, an isochoric process, and an adiabatic process (see figure). At A, the temperature of the gas is T . What is the change in the internal energy of the gas, in the units of RT (R is the universal gas constant) as the system goes from A to B

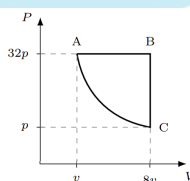

ANS: 10.50